



The Leader in Architectural Audio™

PN. 33-2528

INTRODUCTION

Thank you for purchasing the Sonance Ellipse LCR in-ceiling speaker. When properly installed, this product will provide you with years of entertainment pleasure.

To obtain the full potential of your new speakers, please read all instructions before starting the installation. If you do not have the necessary skills to install the speakers yourself, contact your authorized Sonance dealer for installation options.

PARTS LIST

Each Ellipse speaker package includes the following items:

- (1) Sonance Ellipse LCR speaker
- (1) Paintable grille
- (1) Plastic paint plug to protect speaker during painting
- (1) Mounting cutout template (in packaging)

OPTIONAL ACCESSORIES

FlexBracket - part number 91922

Plastic template to reserve a hole in new construction. Designed to be used with the Flexbar mounting system.

Acoustical Enclosure - part number 91921

A 1/2" medium density fiberboard enclosure designed specifically for the Ellipse LCR speaker.

Sonafill in-ceiling - part number 91928

Sonafill is a retrofittable acoustical treatment for that virtually eliminates the noise produced by resonating drywall and dramatically improves mid-bass sound quality

RECOMMENDED PLACEMENT

The design of many homes today leaves little space for box or in-wall LCR speakers. The use of in-ceiling LCR speakers has become quite common in the last few years. Most of these installations have used speakers not well suited for this purpose. The Ellipse LCR was specifically designed to solve this problem.

The most important consideration when using in-ceiling LCR speakers is maintaining good cohesion between picture and sound. As a general rule you should try to install the speakers no more than 4 to 6 feet away from the top of the television. In a room with 8 foot ceilings and using a rear projection or large tube television this should be very easy.

Using the following recommendations will insure your installation achieves maximum performance from the speakers.

INSTALLATION INSTRUCTIONS

SONANCE ELLIPSE LCR IN-CEILING SPEAKER

RECOMMENDED PLACEMENT CONTINUED

Proper placement of the Ellipse LCR is critical for maximum performance. Try to apply as many of the following recommendations in your installation.

The speakers should be located from eight to eighteen feet from the listener. The minimum recommended spacing from speaker to listening position would be approximately 6 feet in a room with eight foot ceilings. The height and size of the television will largely determine this distance. Keep in mind that if the television is placed at eye level and the speakers are installed less than six feet in front of the listening position the picture and sound could seem very disconnected.

If possible the speakers should be located a minimum of three to four feet from the front wall this is the wall the television is on.

The left and right speakers should be separated approximately eight to twelve feet apart with the center speaker placed as close to the middle as possible. The Sonic Eye on all three speakers should be pivoted toward the listening position.

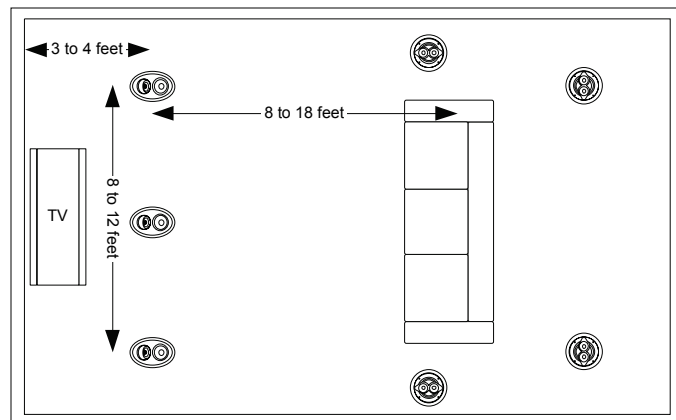
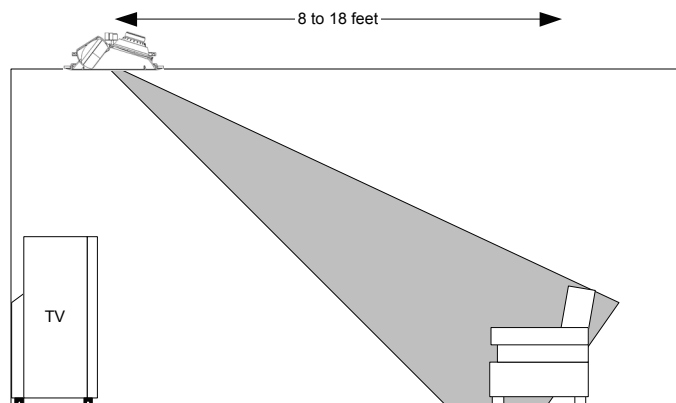

Left Center Right Speaker Placement

WIRE GAUGE AND QUALITY

The total wire resistance should be less than 10% of the speaker impedance. If using an 8 ohm speaker, your total wire resistance should be no more than 0.8 ohms.

In simple terms, the extra resistance from the wire will have a very negative affect on the sound quality of the speaker. The sound can be less dynamic, definition of bass frequencies can be reduced, and in extreme cases, the high frequencies can be attenuated. Amplifier power is also wasted in the wire, reducing the maximum output level of the system.

Please refer to the following chart when deciding on the appropriate wire gauge for your installation.

Wire resistance in Ohms vs. length of cable run						
Distance in Feet	50'	100'	150'	200'	250'	300'
20 gauge	.86	1.73	2.59	3.45	4.32	5.18
18 gauge	.65	1.30	1.94	2.59	3.24	3.89
16 gauge	.43	.85	1.28	1.71	2.14	2.56
14 gauge	.27	.54	.81	1.08	1.35	1.62
12 gauge	.17	.34	.51	.68	.85	1.02
10 gauge	.11	.22	.33	.44	.56	.67

PREPARING THE INSTALLATION LOCATION

All Sonance speakers are designed to be relatively insensitive to changes in enclosure volume. To achieve the ultimate performance from the Ellipse LCR speaker, a section of the ceiling bay can be sectioned off to form a back box. Building this enclosure will create a dramatic improvement in the quality of bass response and power handling.

Ideal Back box volume:

Ellipse 1.0 LCR	1.00 cubic feet (28.3 liters)
Ellipse 2.0 LCR	1.25 cubic feet (35.4 liters)

Insulating the ceiling cavity

Speaker performance can be enhanced by insulating the cavity with fiberglass insulation.

When installing speakers in a ceiling, it is best to lay a sheet of unfaced fiberglass insulation over the back of the speaker.

To further improve the sound quality, install insulation in the bays adjacent to the speaker location. This will reduce noise produced by the unsupported drywall.

Sonafill®

Sonafill is a retrofitable acoustical treatment for loudspeakers that virtually eliminates the noise produced by resonating drywall and dramatically improves mid-bass sound quality. Sonafill also reduces room-to-room noise especially in multi-channel installations where many speakers are installed.

The Sonafill system consists of two pillows and four tiles. Installation is accomplished by first adhering the tiles to the inside of the cavity, then stuffing the two pillows in place behind the tiles.

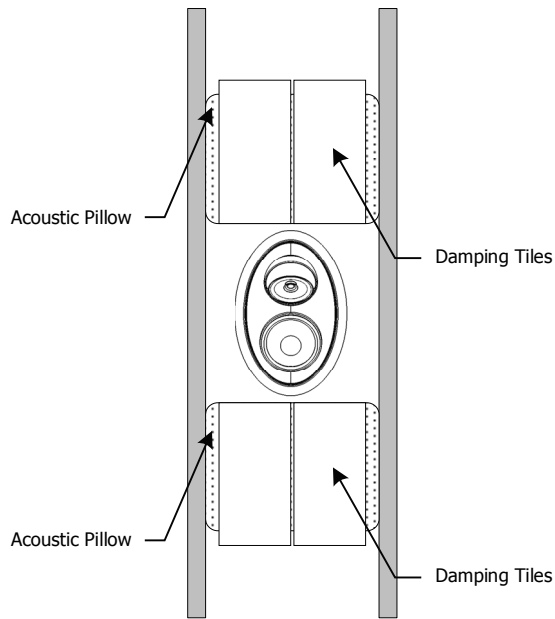
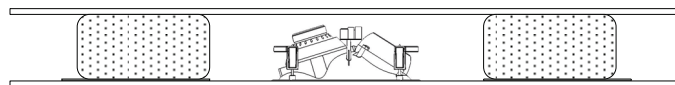

The Sonafill System

New Construction

The Ellipse LCR speaker features an integral FlexBar® mounting system for quick mounting into ceilings. The Ellipse FlexBracket is only necessary in new construction installations when reserving a location for the speaker is desired.

The FlexBracket will serve as a guide for the drywall installer when cutting holes for in-ceiling speakers. The FlexBracket can be nailed, screwed or stapled to the joists so that the hole is in the desired location once the drywall is installed.

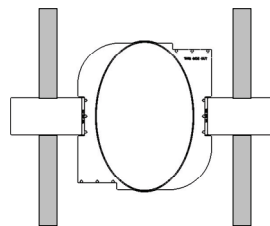

Ellipse FlexBracket

Retrofit

With the FlexBar system, the speaker can be installed directly into existing ceilings. Once the hole is cut and the cable is run, the speakers can be installed in a matter of seconds.

Once you have determined the area you would like to locate your speakers, you will need to do an obstruction survey. Before you cut the hole for the speaker, be certain no joist, conduit, pipe, heating duct or air return will interfere with the speaker.

A cut out template is provided in the packaging of the speaker. Position the template where the speaker is to be located and pencil an outline on the ceiling. If you are unsure about obstructions drill a small hole in the center of the circle and insert a coat hanger into the hole to feel for possible obstructions. If no obstructions are found, proceed with cutting the hole using a drywall saw and run the speaker wires.

INSTALLING THE SPEAKERS

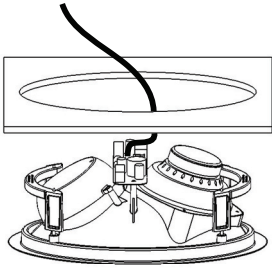

Step 1

Remove the paint plug from the speaker. Attach the wire from your amplifier to the terminals on the back of the speaker. Double check the polarity of the speaker wires, amplifier + to speaker + and amplifier - to speaker -. Proper polarity is critical in home theater installations.

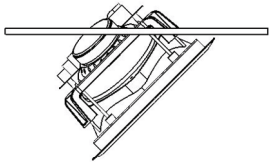

Step 2

To install the Ellipse LCR, insert one side of the Flexbar clamps through the hole in the drywall. Once the feet are through the hole, insert the other side of the Flexbars into the cutout.

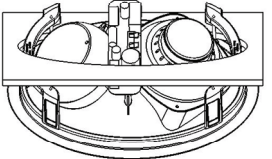

Note: The maximum clamp thickness is 1-1/4" (32mm)

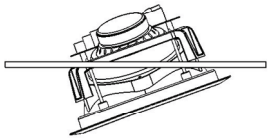

Step 3

Tighten the four screws on the front of the baffle. The Flexbars will automatically begin clamping the speaker. When you notice resistance on the four screws, the speaker has been clamped successfully.

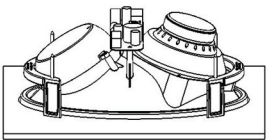

The flange is designed to flex and conform to any small imperfections in the wall surface. The screws should not be tightened so far that the flange bows out.

Step 4

After the four Flexbar screws are tightened the grille can be installed. Insert about half of the grille into the groove at the edge of the speaker. Gently fit the remaining half of the grill into the speaker by working your hands around the speaker fitting the grille into the groove as you go along.

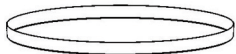
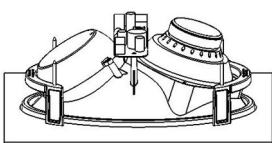

Note: The torque applied to the mounting screws can be adjusted for proper grille fit.

PAINTING THE SPEAKERS AND GRILLES

Speakers and grilles can be painted before installation, which will eliminate the "paint scar" if the speaker needs to be removed for service. Speakers may also be painted after installation, but before the grilles are attached. All speakers come from the factory fitted with a plastic "paint plug." Use the paint plug to protect the drivers while the flange is being painted with the ceiling.

Sonance suggests always painting the grilles separate from the speaker. The grilles may be lightly sprayed with thin paint (5 parts thinning agent to 1 part paint), but be careful not to plug the holes. Too much paint will adversely affect the sound of the speaker.

Once the grilles and flange are painted and dry, remove the paint plug from the flange and install the grilles.

ADJUSTING YOUR SPEAKERS

The Sonic Eye

The unique sealed pivoting enclosure can direct sound toward or away from the listening area. To pivot the Sonic Eye, apply light pressure to the tweeter ring and the outside edge of the midrange. Do not apply pressure to the midrange cone or the tweeter dome. If you have any questions about how the Sonic Eye should be adjusted, consult your authorized Sonance dealer.

Here are some suggestions:

Orient the Sonic Eye toward the listening area if the speakers are widely separated and the music fails to blend into a central image when the system is operated in stereo.

When using the Ellipse LCR in a home theater, point the Sonic Eye on all three speakers towards the listening position for more accurate sound.

Ellipse 1.0 LCR

Speaker Design	In-ceiling LCR infinite baffle
Tweeter	1/2" (13mm) Cloth dome, pivoting
Midrange	4" (102 mm) Polypropylene cone, pivoting
Woofer	6-1/2" (165 mm) Black glass composite cone with a rubber surround
Frequency Response	50Hz – 20kHz ±3dB
Impedance	8 ohms nominal, 6 ohms minimum
Power	5 watts minimum; 125 watts maximum
Sensitivity	89dB 1W / 1m
Grille	Aluminum
Speaker Dimensions	10-1/2" (267mm) x 15-1/2" (394mm) x 5-7/8" (149mm)
Cutout Dimensions	9" (171mm) x 14" (356mm) elliptical
Weight	8.0 lbs (3.63 kg) each

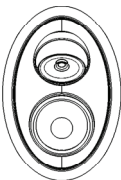

Ellipse 2.0 LCR

Speaker Design	In-ceiling LCR infinite baffle
Tweeter	1" (25mm) Aluminum dome, pivoting
Midrange	4" (102 mm) Aluminum cone, pivoting
Woofer	6-1/2" (165 mm) Black aluminum cone with a rubber surround and extended pole piece
Frequency Response	40Hz – 20kHz ±3dB
Impedance	6 ohms nominal, 4 ohms minimum
Power	5 watts minimum; 150 watts maximum
Sensitivity	90dB 1W / 1m
Grille	Aluminum
Speaker Dimensions	10-1/2" (267mm) x 15-1/2" (394mm) x 5-7/8" (149mm)
Cutout Dimensions	9" (171mm) x 14" (356mm) elliptical
Weight	9.0 lbs (4.1 kg) each

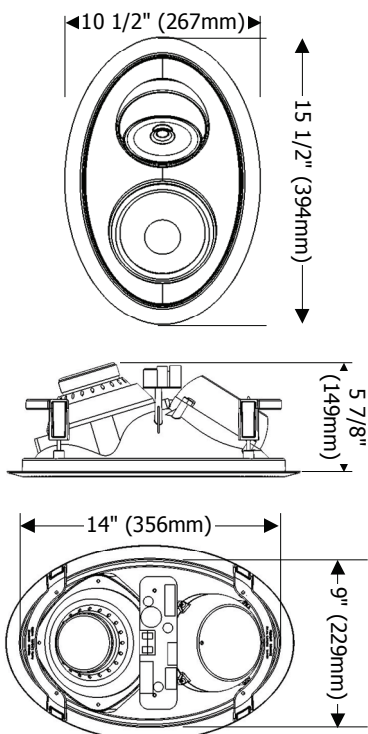
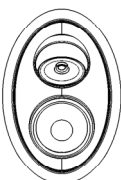

TECHNICAL ASSISTANCE AND SERVICE

The Technical Assistance Department at Sonance is available at (800) 582-0772 or (949) 492-7777 to answer any questions concerning the operation and installation of your speakers between the hours of 7:00 AM and 5:00 PM Pacific time, Monday through Friday, except holidays.

In the event your unit should need repair or service, you may return the unit to your authorized dealer or use the following guidelines:

1. Be prepared to state the model number and / or serial number, date of purchase and dealer's name and address when calling.
2. Contact Sonance directly at (800) 582-0772 or (949) 492-7777 or at www.sonance.com
3. If you are returning the product directly to Sonance, call us to obtain a return authorization number before shipping. **YOU MUST HAVE PRIOR AUTHORIZATION TO RETURN YOUR UNIT.**
4. The original packaging must be used. If the original packaging is unavailable, replacements can be obtained from Sonance for a small fee.
5. Ship the product via a package delivery service such as UPS or Federal Express. Please do not use the U.S. Postal service.
6. Write the return authorization number on the outside of the box.
7. Ship to:
Attn: Quality Assurance Department
Sonance
212 Avenida Fabricante
San Clemente, CA 92672-7531
8. **FREIGHT COLLECT SHIPMENTS WILL BE REFUSED !**

Limited Lifetime Warranty

Sonance warrants to the original retail purchaser only that this Sonance product will be free from defects in materials and workmanship, provided the speaker was purchased from a Sonance Authorized Dealer after September 1, 2003. Purchases made before that date carry a limited 5 year warranty.

Defective products must be shipped, together with proof of purchase, prepaid insured to the Sonance Authorized Dealer from whom they were purchased, or to the Sonance factory at the address listed on this installation instruction manual. Freight collect shipments will be refused. It is preferable to ship this product in the original shipping container to lessen the chance of transit damage. In any case, the risk or loss or damage in transit is to be borne by the purchaser. If, upon examination at the Factory or Sonance Authorized Dealer, it is determined that the unit was defective in materials or workmanship at any time during this warranty period, Sonance or the Sonance Authorized Dealer will, at its option, repair or replace this product at no additional charge, except as set forth below. If this model is no longer available and can not be repaired effectively, Sonance, at its sole option may replace the unit with a current model of equal or greater value. In some cases where a new model is substituted, a modification to the mounting surface may be required. If mounting surface modification is required, Sonance assumes no responsibility or liability for such modification. All replaced parts and product become the property of Sonance. Products replaced or repaired under this warranty will be returned to the original retail purchaser, within a reasonable time, freight prepaid.

This Warranty does not include service or parts to repair damage caused by accident, disaster, misuse, abuse, negligence, inadequate packing or shipping procedures, commercial use, voltage inputs in excess of the rated maximum of the unit, or service, repair or modification of the product which has not been authorized or approved by Sonance. This Warranty also excludes normal cosmetic deterioration caused by environmental conditions. This Warranty will be void if the Serial Number on the product has been removed, tampered with or defaced. This Warranty is in lieu of all other expressed warranties. If the product is defective in materials or workmanship as warranted above, the purchaser's sole remedy shall be repair or replacement as provided above. In no event will Sonance be liable for any incidental or consequential damages arising out of the use or inability to use the product, even if Sonance or a Sonance Authorized Dealer has been advised of the possibility of such damages, or for any claim by any other party.

Some states do not allow the exclusion or limitation of consequential damages, so the above limitation and exclusion may not apply. All implied warranties on the product are limited to the duration of this expressed Warranty. Some states do not allow limitation on the length of an implied warranty. If the original retail purchaser resides in such a state, this limitation does not apply.

w w w . s o n a n c e . c o m